

# SNAP Simple Brain

## Features

- 10/100 Mbps Fast Ethernet network connectivity
- Use SNAP analog, digital, and serial modules in any position on a single 16-module mounting rack
- Simultaneous communication using Modbus/TCP, OPC, and other applications you develop.

## Description

**NOTE:** *Although fully supported and still in production, this is a legacy product and not recommended for new designs. For new designs, the **SNAP-PAC-EB2 brain** offers similar capabilities plus several additional features.*

Opto 22 SNAP Simple I/O™ is a low-cost solution that brings you Ethernet/TCP communications as well as analog, simple digital, and serial capability on the same mounting rack.

Used for high-density commercial and industrial applications and for remote monitoring applications with high I/O point counts, a SNAP Simple I/O unit consists of a SNAP-ENET-S64 brain mounted on a SNAP M-series rack with SNAP I/O™ modules. These analog, standard digital, high-density digital, and serial modules can be mounted in any position on the rack (8 serial modules maximum).

SNAP Simple I/O can act as part of a SNAP control system, or it can act as an independent I/O unit. As a distributed I/O unit in a SNAP control system, SNAP Simple I/O is controlled by a SNAP PAC, SNAP-LCE, or SNAP Ultimate controller.

As an independent I/O unit, SNAP Simple I/O communicates using Modbus/TCP, OptoOPCServer, or applications you develop using the free OptoMMP Communication Toolkit. The brain also supports data streaming.

The SNAP-ENET-S64 brain provides both 10 and 100 Mbps Fast Ethernet compatibility, with automatic speed negotiation and a standard RJ-45 twisted-pair connector. The brain also includes a serial port for programming and diagnostics.

Simple I/O brain functions include the following:

- **Digital**—Input latching, on/off status, and watchdog timer.
- **Analog**—Thermocouple linearization (32-bit floating point for linearized values), minimum/maximum values, offset and gain, scaling, time-proportional output, filter weight, output clamping, and watchdog timer.



SNAP Simple Brain

- **Serial**—Ability to send and receive ASCII strings to and from attached serial devices, such as chart recorders and barcode readers.

Each SNAP standard digital module contains four input or four output points. SNAP high-density digital modules provide 32 inputs or outputs per module. The number of points on each SNAP analog or serial module varies depending on the module.

**Notes for legacy products:** The SNAP Simple brain can be used with newer SNAP PAC racks as well as legacy M-series racks. It can be used with the current PAC Project or legacy ioProject software suites, although some features in PAC Project are not supported by this brain. For important information on mixing legacy and current products, see Opto 22 form #1688, the *SNAP PAC System Migration Technical Note*.

For a detailed comparison of SNAP Simple brains with other SNAP brains, see Opto 22 form #1693, *Legacy and Current Product Comparison and Compatibility Charts*

All documents are available on our website, [www.opto22.com](http://www.opto22.com). The easiest way to find one is to search on its form number.

## Part Numbers

Part	Description
SNAP-ENET-S64	SNAP Simple Ethernet I/O Brain, Analog/Simple Digital/Serial

## Description (continued)

## Specifications

Power Requirements	5.0 VDC ± 0.1 VDC at 1.2 A maximum (does not include module power requirements)
Operating Temperature	0 °C to 70 °C
Storage Temperature	-40 °C to 85 °C
Humidity	0–95% humidity, non-condensing
Network Interface	IEEE 802.3 network, 10Base-T and 100Base-TX
Serial Port	RS-232 (for programming and diagnostics only)
Serial Data Rates	Default is 19,200 kBd; baud rate is soft-selectable from 2400 to 115,200 kBd.
Maximum Ethernet Segment Length	100 meters with Category 5 or superior UTP. For 100 Mbps at this distance, use Category 5 or superior solid UTP.
Jumpers (Internal)	Boot to kernel/boot to loader Reset to factory defaults

### Serial Connector Pinouts

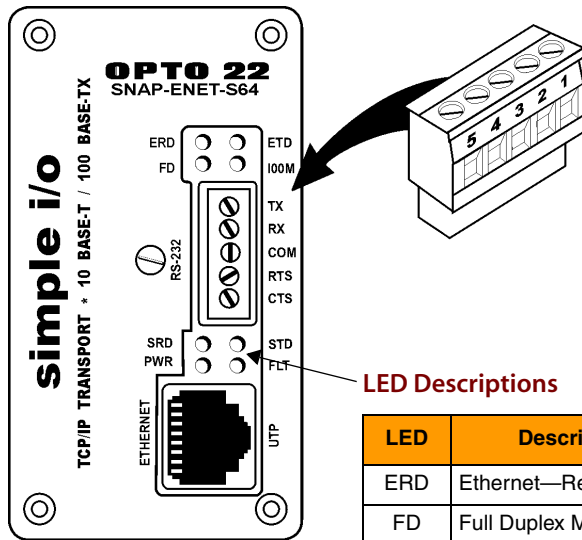

### LED Descriptions

LED	Description
ERD	Ethernet—Receive Data
FD	Full Duplex Mode
SRD	Serial—Receive Data
PWR	Power On

### RS-232 Serial Cable

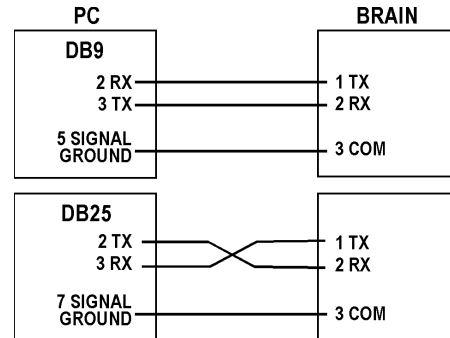

LED	Description
ETD	Ethernet—Transmit Data
100M	Ethernet Link Detection at 100 Mbps
STD	Serial—Transmit Data
FLT	Microprocessor Status or Fault

# SNAP Simple Brain

## Dimensional Drawing

**OPTO 22**

**SNAP Simple Brain**

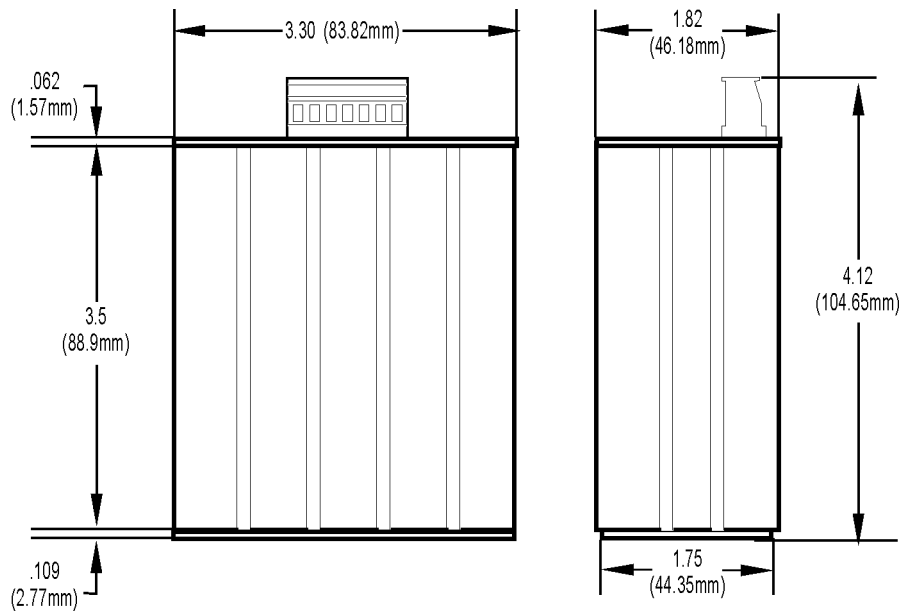
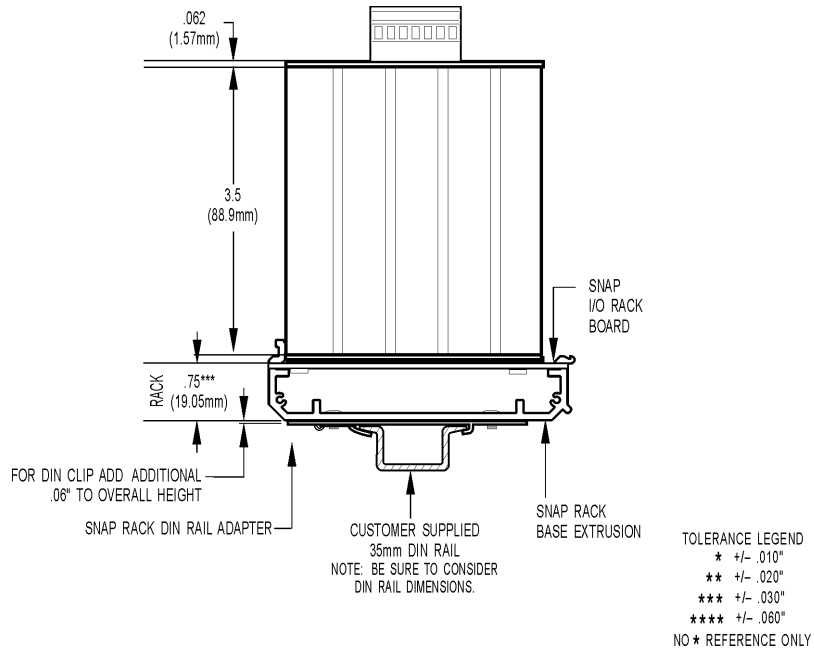

DATA SHEET  
Form 1452-070723

PAGE

4